

2016 BRINGING ADMINISTRATORS TOGETHER CONFERENCE

START myResearch – myDisclosures (COI)

April 14, 2016

UIC UNIVERSITY OF ILLINOIS
AT CHICAGO

UIC

Lincoln Hall

707 South Morgan Street

Workshop Presenter(s)

Name: Sean Ireland

Title: Enterprise System Specialist

Contact Information: sireland@uillinois.edu

Please ...

- Turn off cell phones.
- Avoid side conversations.
- Ask questions at any time.
- Sign the attendance roster.
- Complete the evaluation at the end of the workshop.

Workshop Objectives

- Understand the overall objective, scope, and roadmap of the START myResearch Project.
- Understand myDisclosures (COI) plans for 2016 and beyond, as a subset of START myResearch Project.
- Understand myDisclosures (COI) may impact you and/or your clients in terms of research support.
- Demonstration

Table of Contents

- START myResearch Project Overview
- START myResearch Project High Level Roadmap – Past, Present, and Future
- myDisclosures (COI) Demonstration

START myResearch Overview

- Purpose:
 - Replace outdated electronic research administration software to better manage ~\$970M* Research Portfolio.
 - Convert paper-based systems and processes to electronic systems.
- START (System-wide Tools for Administration of Research and Training)
 - Pre-Award / Grants Management
 - COI
 - IRB
 - IACUC
- myResearch = Principal Investigator Portal (PI Portal)
 - Central point for faculty members and staff to access information regarding grants, including summary financial data.
 - Display compliance and other information going forward.

Benefits:

- Enable research administrations to efficiently serve and maintain a large and complex sponsored research portfolio.
- Reduce faculty burden and effort.
- Simplify Compliance.
- Drive consensus best practice business processes for University-wide IT support.

START myResearch Project – Releases Completed to date

▲ Release

2013 ~ 2014			2014 ~ 2015			2015 ~ 2016			2016 ~ 2017			2017 ~ 2018		
Fall (Sep, Oct, Nov, Dec)	Spring (Jan, Feb, Mar, Apr, May)	Summer (Jun, Jul, Aug)	Fall (Sep, Oct, Nov, Dec)	Spring (Jan, Feb, Mar, Apr, May)	Summer (Jun, Jul, Aug)	Fall (Sep, Oct, Nov, Dec)	Spring (Jan, Feb, Mar, Apr, May)	Summer (Jun, Jul, Aug)	Fall (Sep, Oct, Nov, Dec)	Spring (Jan, Feb, Mar, Apr, May)	Summer (Jun, Jul, Aug)	Fall (Sep, Oct, Nov, Dec)	Spring (Jan, Feb, Mar, Apr, May)	Summer (Jun, Jul, Aug)

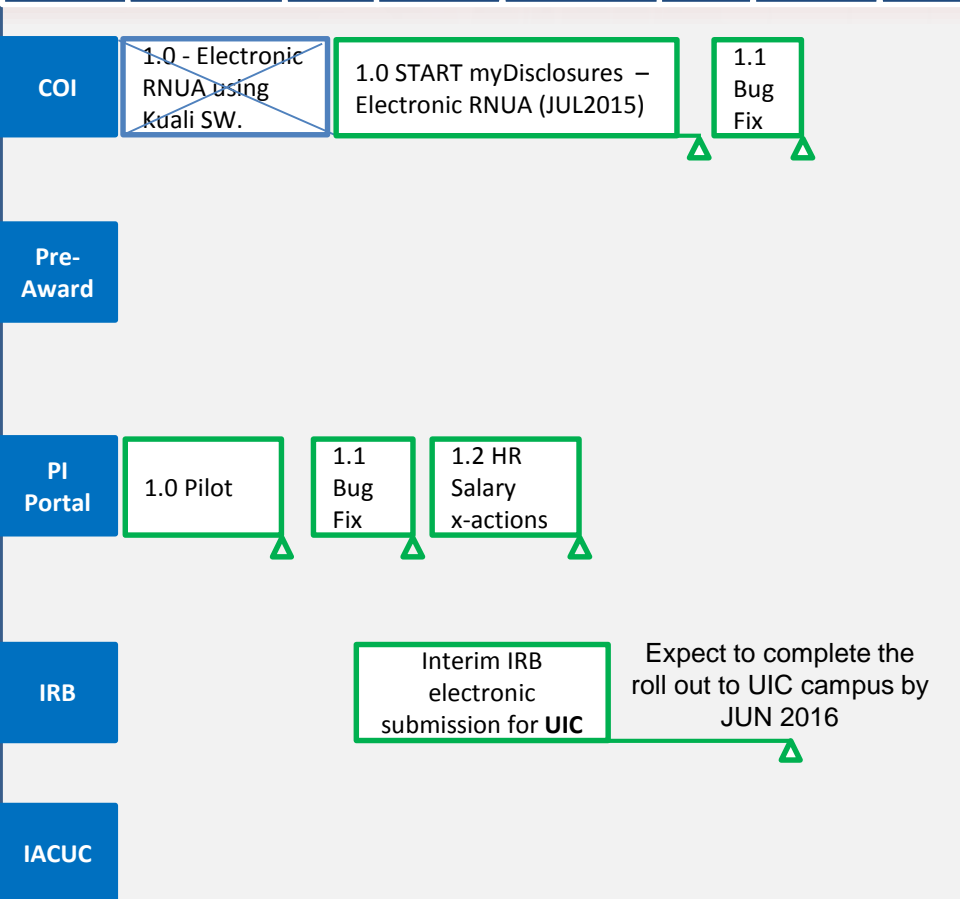

Iterative Release Approach:

1. Balance limited resource and desired release dates by managing scope of work and priorities.
2. Early prototyping – Working software over comprehensive documentation.
3. Review / Collaboration with key stake holders.
4. Repeat until SW is minimally viable to the users.

START myResearch Project - Overall High Level Roadmap

▲ Release

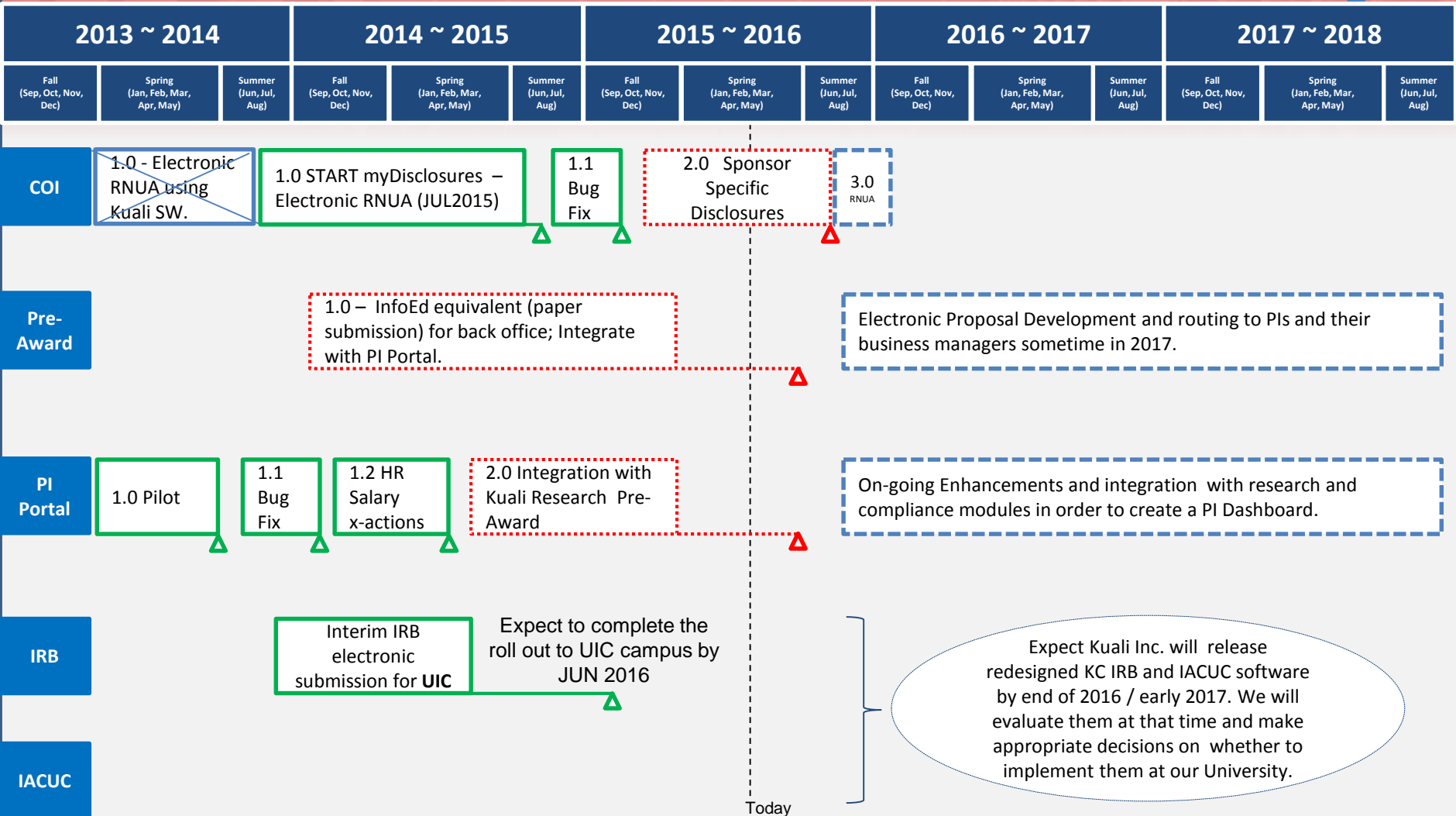

Expect Kuali Inc. will release redesigned KC IRB and IACUC software by end of 2016 / early 2017. We will evaluate them at that time and make appropriate decisions on whether to implement them at our University.

myDisclosures (COI) - Converted Paper RNUA process to Web-based RNUA in the Fall of 2015.

- Paperless system. Over 15,000 RNUA paper submissions eliminated annually.
- Highly accessible. Web based, mobile devices and tablet friendly.
- Automatic electronic routing for approvals.
- A single source to view, manage and track COI disclosures.
- Transparency. All disclosures and conflict information can be tracked.
- Access to prior disclosures. Previously submitted financial entities can be included in future disclosures without needing to manually add each time.

UNIVERSITY OF ILLINOIS
 2015-2016 Report of Non-University Activities (RNUA)
 Disclosure and Request for Prior Approval

Last Name: _____ College(s): _____
 First Name: _____ Dept(s)/Unit(s): _____
 Title/Rank: _____ Appointment: _____
 University Email: _____
 University Contract Period: (check all that apply) Summer Fall Spring / 9 mo 10 mo 12 mo

PART I. Conflict of Commitment and Interest Disclosure
 If you answer "yes" to the question in Part I, then explain the activity in Part II regardless of your percentage of appointment.

Do you have any non-University activities or financial interests, such as the following?

1. **Teaching/Instructor:** You are a paid instructor for credit-bearing college/university course(s) at an institution other than the University of Illinois.
2. **Research/Extension:** You have a non-university financial interest or a fiduciary role with a sponsor of your research, a research sub-recipient, or with an outside entity, organization, or individual related to your University responsibilities.
3. **Business with the University:** You have non-university financial interest or a fiduciary role with an outside entity or organization that does business with the University.
4. **Involvement of University students or employees:** You have non-university financial interest or a fiduciary role involving students or other University employees.
5. **Any other financial interests, commitments, or activities:** You have other non-university financial interests, commitments, or activities (e.g., unpaid jobs) that may present a conflict of commitment or interest with your University of Illinois appointment. Such relationships may include uncompensated activities.
6. **Family ownership interest in an entity doing business with the University:** Any member of your immediate family has any ownership interest or fiduciary role with an outside entity or organization that does business with the University.

Yes (complete Part II & III) **No. I have no activities or financial interest to report.** (skip to Part III)

PART II. Explanation of Non-University Activities
 Report each outside entity, organization, or individual activity or interest separately. If you have more than one activity to report, please use the [RNUA Part II Reporting extra sheet](#) and attach it to your RNUA form.

1. Explanation of activity identified in Part I, applicable number # (check all that apply): 1 2 3 4 5 6
2. Name of Outside Entity, Organization, or individual: _____

UNIVERSITY OF ILLINOIS
 My Disclosures Complete online disclosure reporting

Welcome, Youngwook

My Disclosures looks at your job and research role at the University to determine what disclosures you need to complete.

Learn more about disclosure requirements

My reporting requirements

Answer 4 short questions to determine your reporting requirements

Complete a series of questions for each required disclosure

Review and submit your required disclosures

Determine my requirements

Questions?
 Contact your disclosure facilitator or campus office for help.

UNIVERSITY ADMINISTRATION
 spn@illinois.edu
 217-265-5440

DISCLOSURE FACILITATOR
 Name of person
 Phone

In the process of converting Paper based Significant Financial Interest and Management Plan (SFI – DMP Part 1 and Part II) to Web based in 2016.

- Target Date: June 30th.
- Software: Internally Developed by AITS

Significant Financial Interest – Disclosure and Management Plan (SFI-DMP): Part I
Conflict of Interest

University of Illinois at Chicago
Office of Vice Chancellor for Research
Telephone: (312)996-3642 / 996-4070
Email: COI@uic.edu
Mail Code: M/C 672

First & Last Name	College(s)
University Email	Dept(s)/Unit(s)
Employee's UIN	

A. Disclosure of Sign

I DO NOT HAVE ANY SIGNIFICANT FINANCIAL INTERESTS OR MANAGEMENT PLANS (SFI-DMP) in the preceding 12 months. (If checked, skip to Section 4.)

If the Investigator has more than one relationship with a non-university entity, use one page per external entity. You may use a separate page for each entity.

1. Name of Non-University of Illinois entity
Indicate if this disclosure is new or continuing.

2. Describe the financial relationship with the non-university entity
(check all that apply and complete required disclosures)

a. Remuneration includes salary and other supplemental income
 \$0-\$4,999 \$5,000-\$9,999
 If greater specify: _____
 Value cannot be determined

b. Equity interest includes any stock or other ownership interest
 Total percent owned by you & family: _____
 Entity is: Publicly traded , Non-publicly traded
 If Publicly traded, indicate the value of the interest:
 \$0-\$4,999 \$5,000-\$9,999
 If greater specify: _____
 Value cannot be determined

c. Intellectual property rights and management plan
 University of Illinois to the extent of the management plan

d. Fiduciary role (e.g. executive role)

e. Other. Describe: _____

3. In the past 12 months, did the external entity pay you or your family?
 Purpose of the trip(s): _____
 Destination(s): _____
 Duration (total # of days): _____
 Aggregate value of the travel expenses:
 \$0-\$4,999 \$5,000 - \$9,999 \$10,000 or more
 If greater, specify amount: _____
 Value cannot be determined by respondent

4. Describe how the financial interest is or was managed

UNIVERSITY OF ILLINOIS
START myDisclosures Complete online disclosure reporting

Welcome, Youngwook .
START myDisclosures looks at your job and research role at the University to determine what disclosures you need to complete.

My reporting requirements

My Status

According to my answers, I am:

- Academic Staff / Academic Professional / Faculty / Postdoctoral Associate
- An Investigator or key research personnel on a pending or existing research project that is sponsored by any organization that applies the 2011 PHS Regulations on FCOI.
- An Investigator or key research personnel on a pending or existing award that is sponsored by any organization that applies the NSF rules for FCOI.
- Paid on the same sponsored research award as a member of my family.

If any of these statements are incorrect, update them now:

I need to complete:

- Report of Non-University Activities
Start new
Needs to be completed
- Sponsor Disclosure
Resume New Disclosure
Begin Management Plan
Saved - Needs to be completed
- Nepotism Disclosure
Start
Will be completed outside START myDisclosures

Thank You!

- START myResearch Website
 - http://web.uillinois.edu/start_myresearch/
- myDisclosures (COI)
 - <https://myresearch.uillinois.edu/myDisclosures/>

Questions / Concerns?